

- Single-Phase vacuum cleaner with 3 Bypass Motors for Superior Suction Power.
- Vacuum Cleaner for Dust and Liquids, Ideal for Various Cleaning Applications.
- Quick Release Container for Easy Waste Disposal.

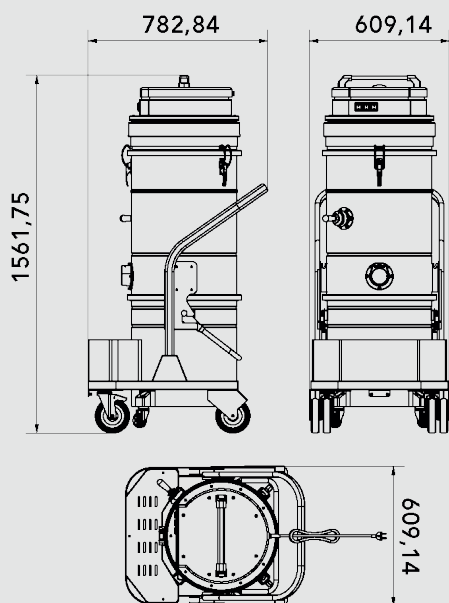

[INFO@COYNCO.COM](mailto:INFO@COYNCO.COM)

[WWW.COYNCO.COM](http://WWW.COYNCO.COM)

All information in this document is subject to change without notice.

TYPE	<b>BASIC</b>
PRODUCT	<b>WM 375 BASIC</b>
VACUUMED MATERIAL	DUST AND LIQUIDS
MOTORIZATION	NR 3 BY-PASS
POWER	3300 W
VOLTAGE	230 V
FREQUENCY	50 / 60 HZ
AMPS	14,4 A
AIR FLOW	510 M3/H
DEPRESSION	230 MBAR
VALVE DEPRESSION	-
SUCTION INLET	TYPE C CENTRAL 70 MM
DIMENSIONS	80X60 H152 CM
WEIGHT	67 KG
FILTER CHAMBER DIAMETER	D. 460 MM
TANK AND LONGOPACK INTERCHANGEABILITY	NO
FILTER TYPE	STAR POLYESTER
ELECTRIC FLOATER	OPTIONAL
DISCHARGE SYSTEM	-
FILTERING SURFACE	20.000 CM2 - 30.000 CM2 OPTIONAL
FILTER CLEANING	MANUAL
HEPA ABSOLUTE FILTER	OPTIONAL H13 / 99,95% MPPS 0,12 MY
HEPA FILTERING SURFACE	-
SLURRY FILTRATION GRADE	-

## PACKAGING



TYPE	NO. MACHINES	DIMENSIONS PACKAGE	WEIGHT
BOX	1	90X70 H190 CM	-
PALLET	1	90X70 H190 CM	80 KG
PALLET			